

**CODE CNIM :**

--	--	--	--	--	--	--	--

CONCOURS 2019

**ÉPREUVE DE SCIENCE DE L'INGENIEUR**

**Modélisation du système d'orientation des roues :**

1.

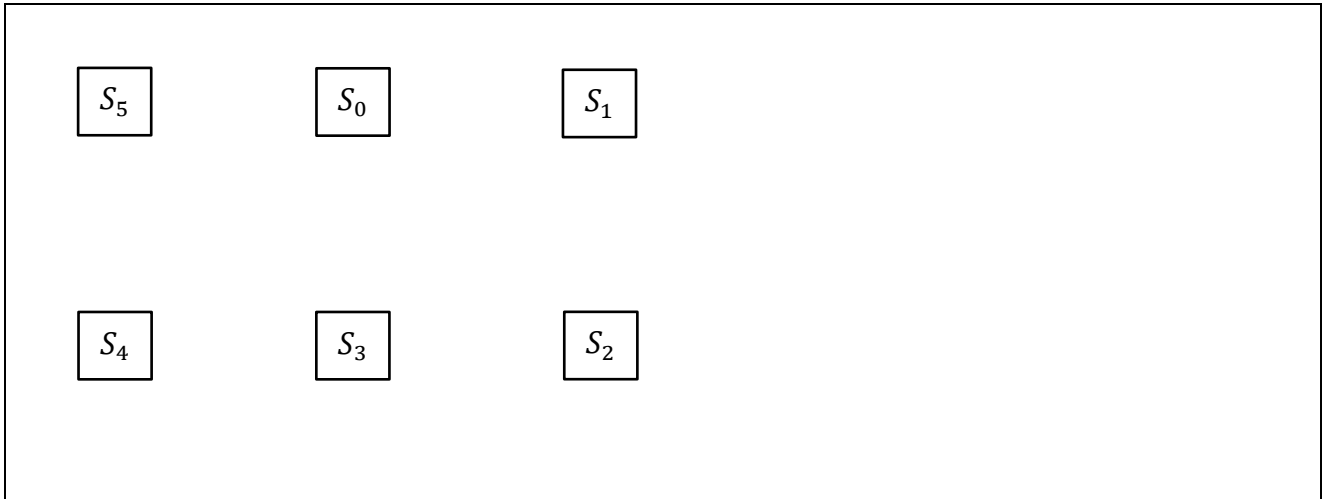

2.

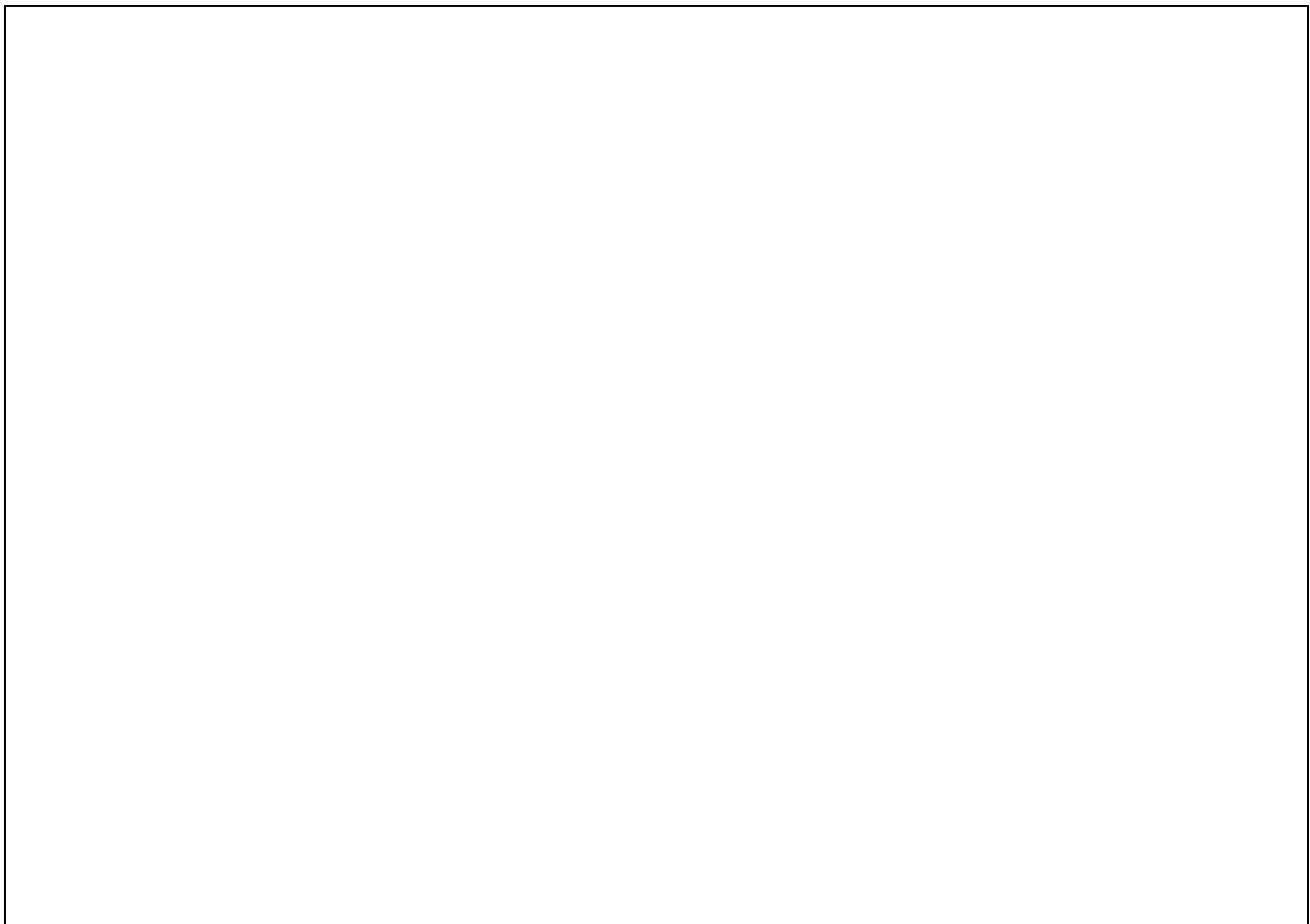

3.

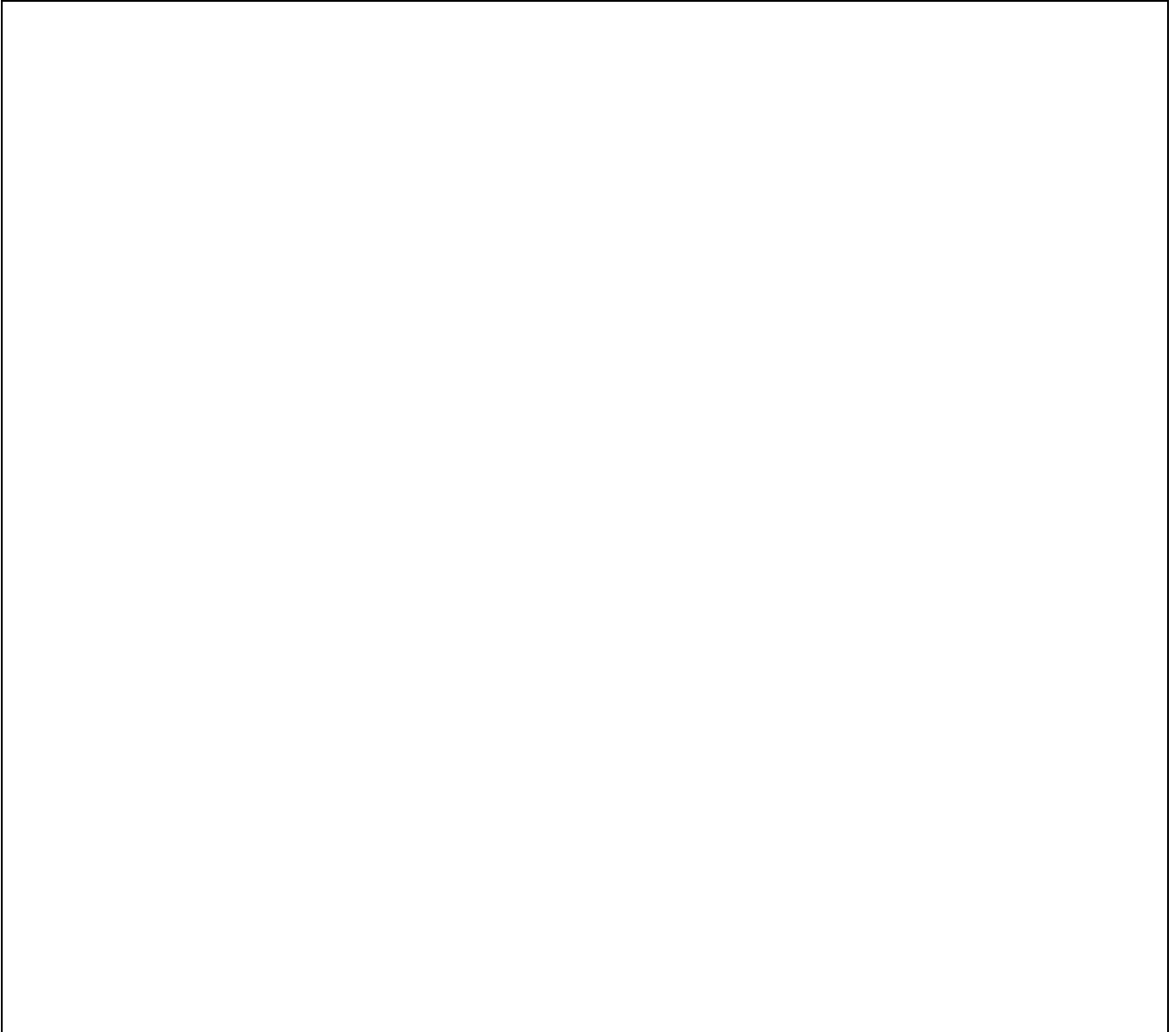

4.



5.



6.



7.

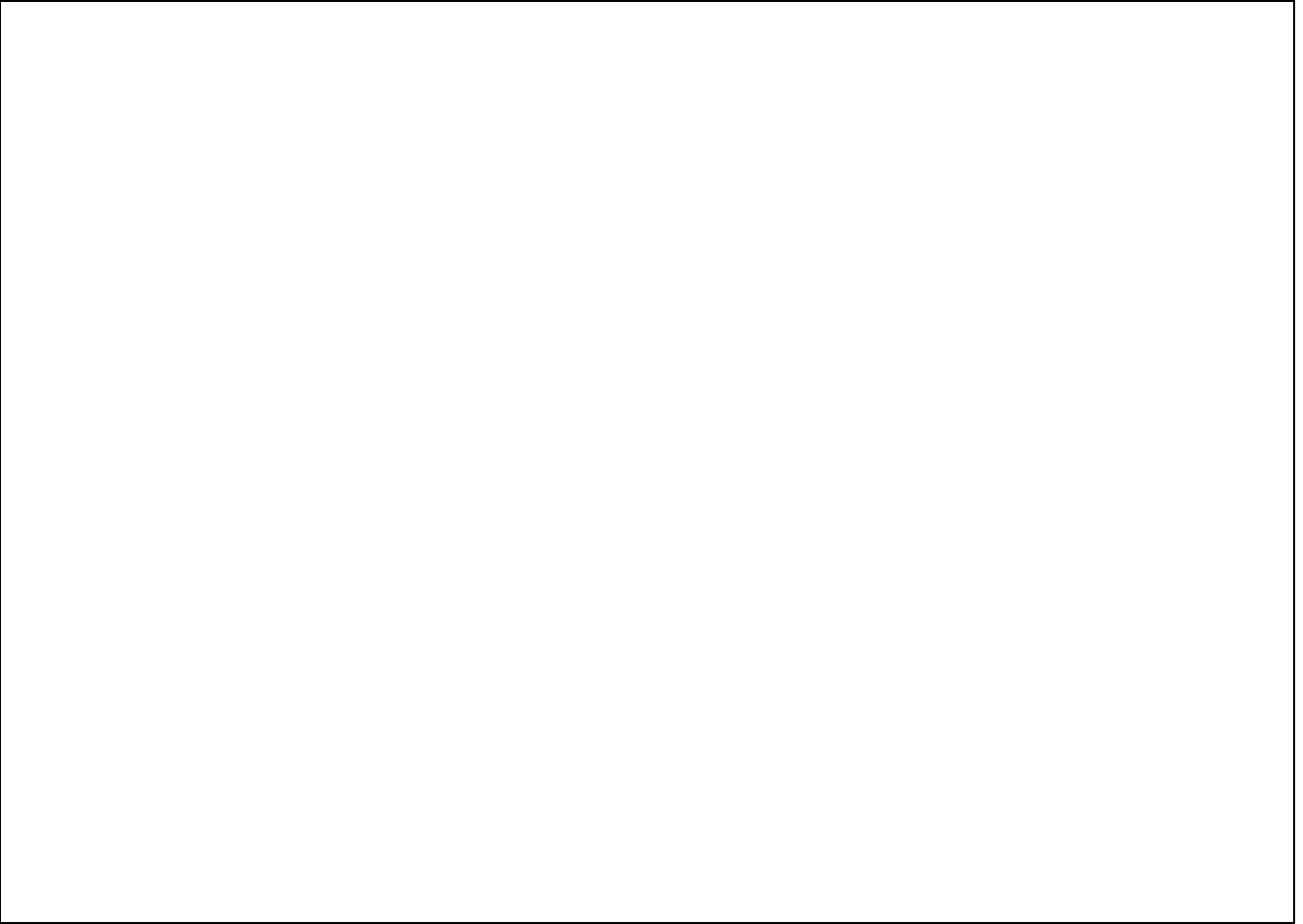

8.



9.

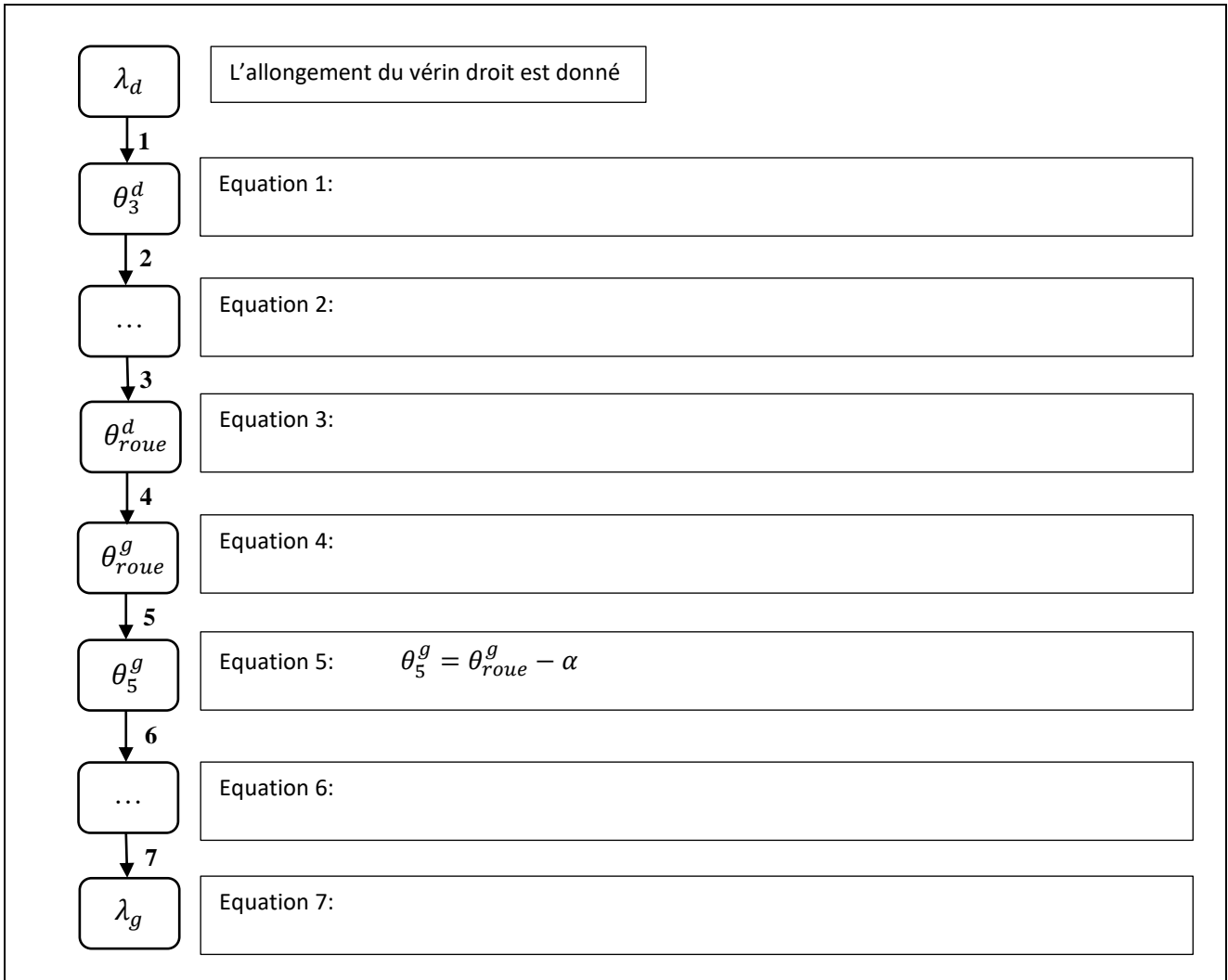

10.



**Vérification des performances des élingues de levage :**

11.

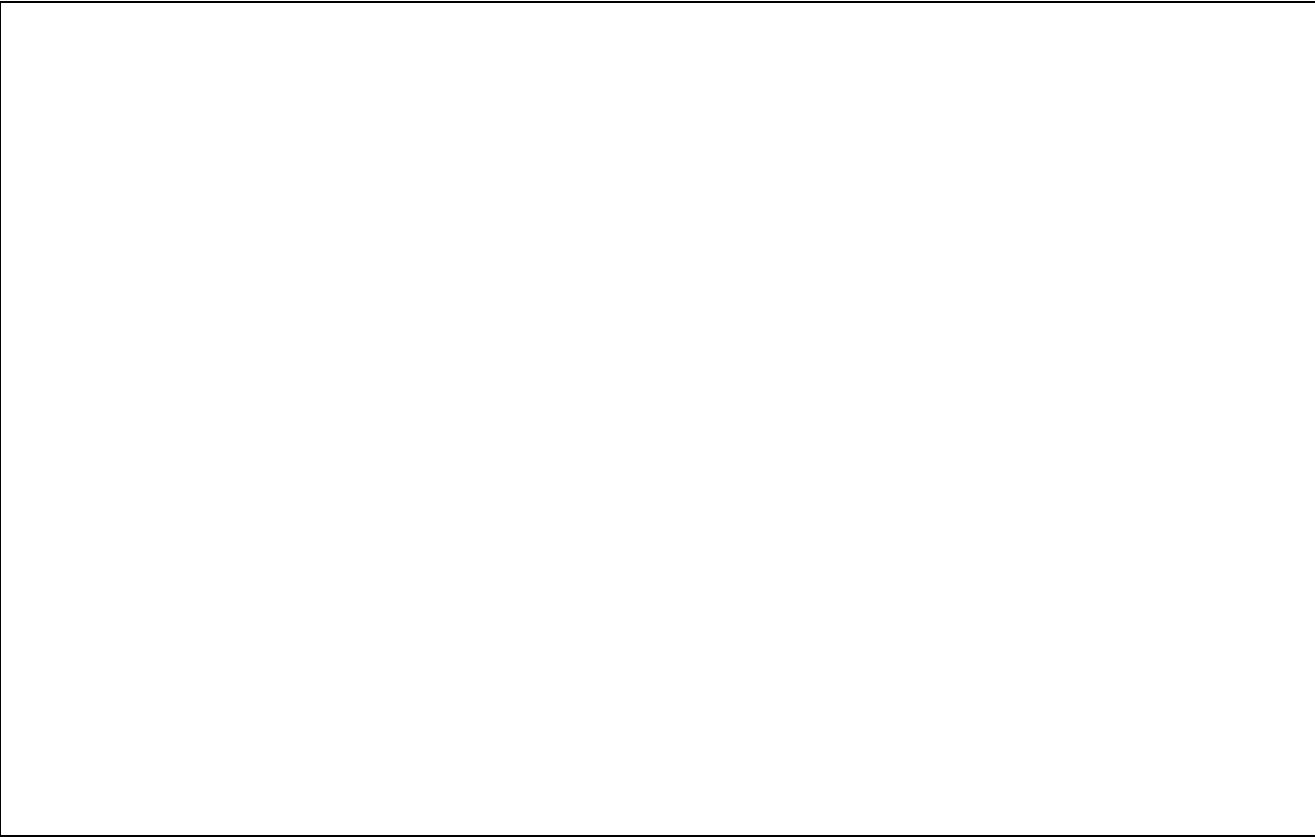

12.



## Vérification des performances du treuil hydraulique

Couple moteur :

13.

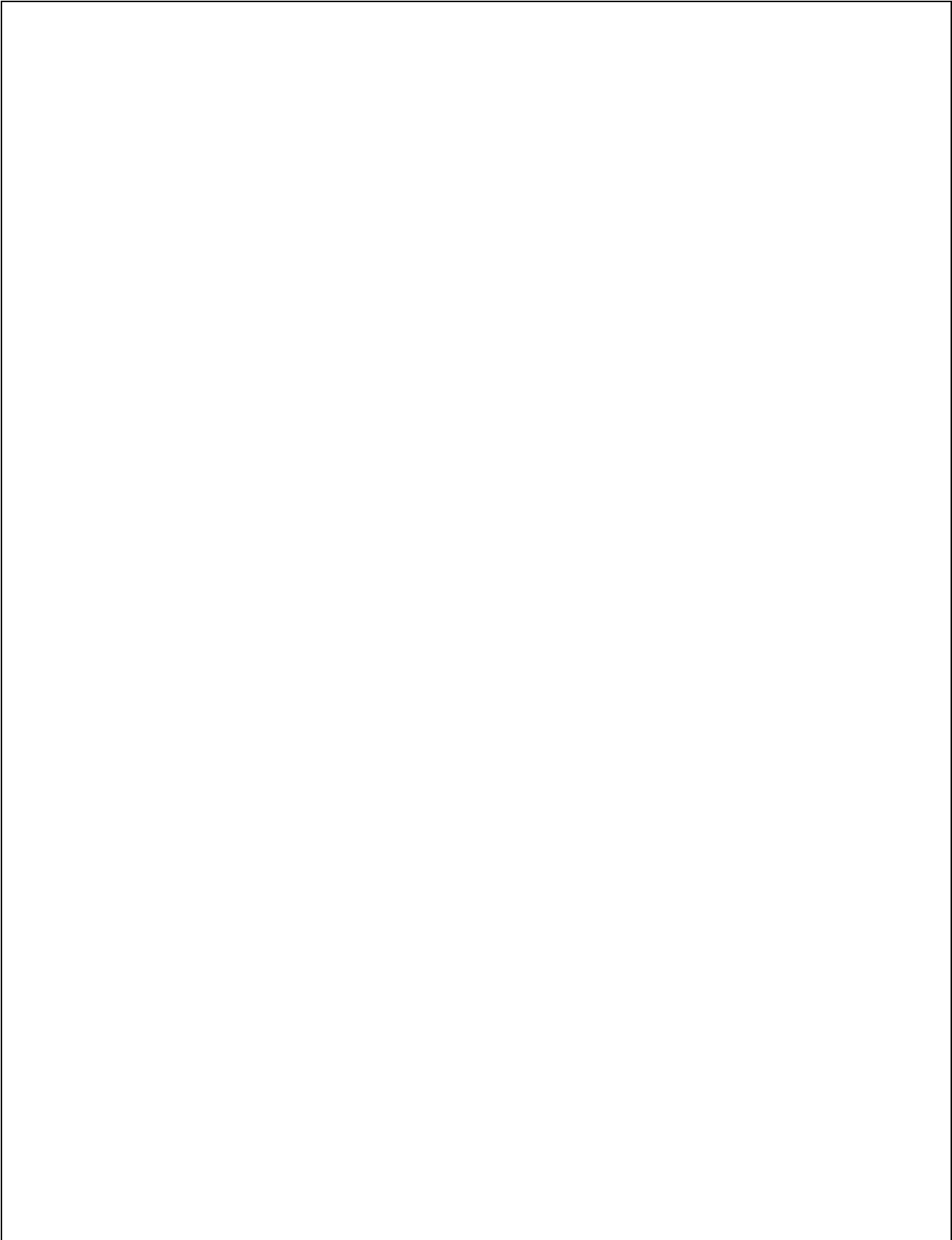

14.

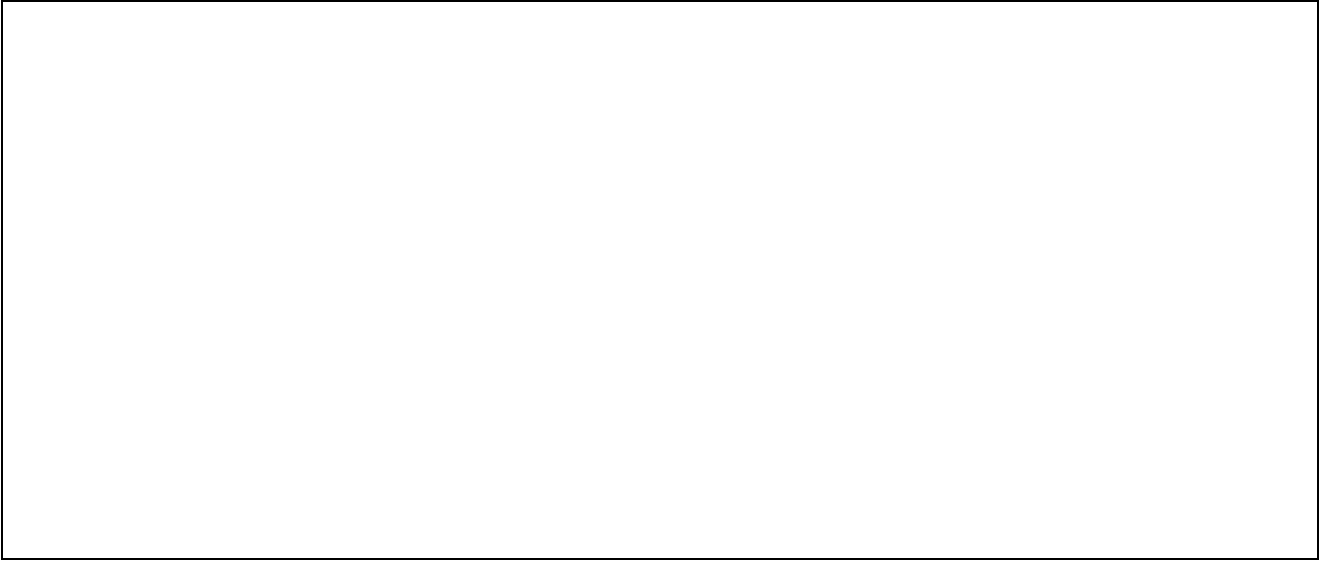

15.



16.

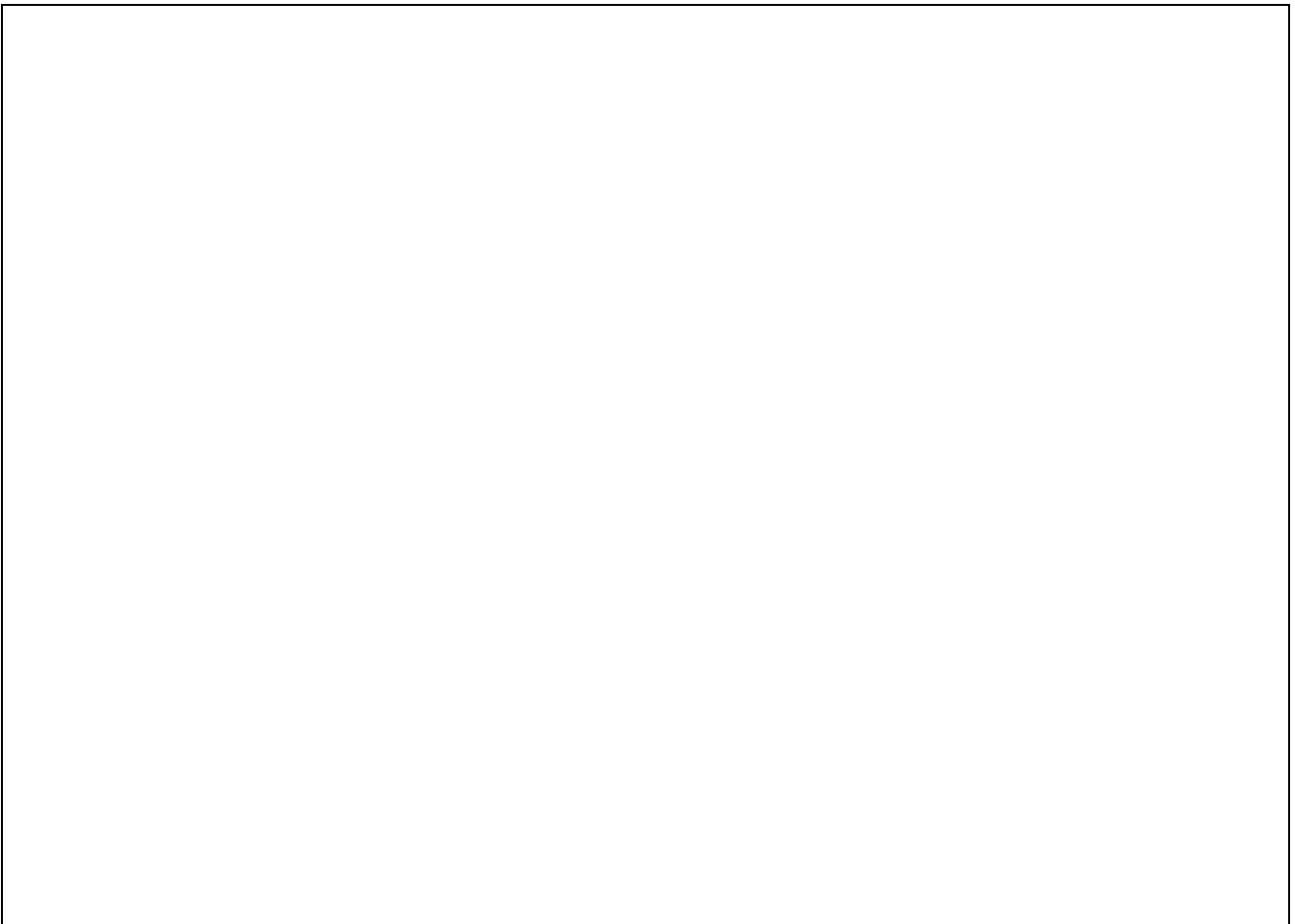



17.

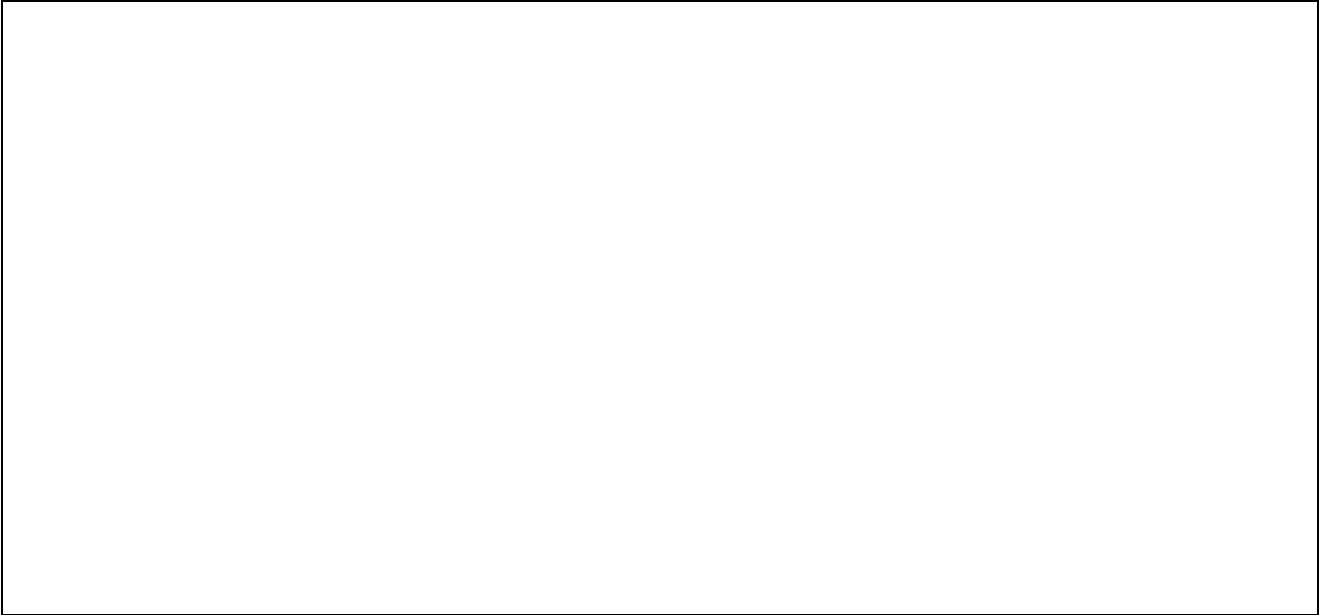

18.



Asservissement de la vitesse de levage du bateau :

Modélisation du système (Pompe + Vérin + Valve) :

19.

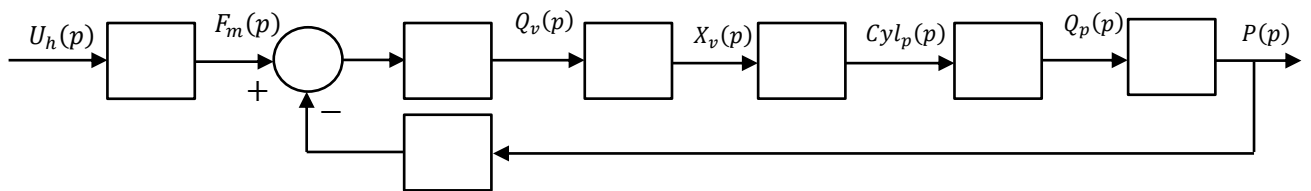

20.

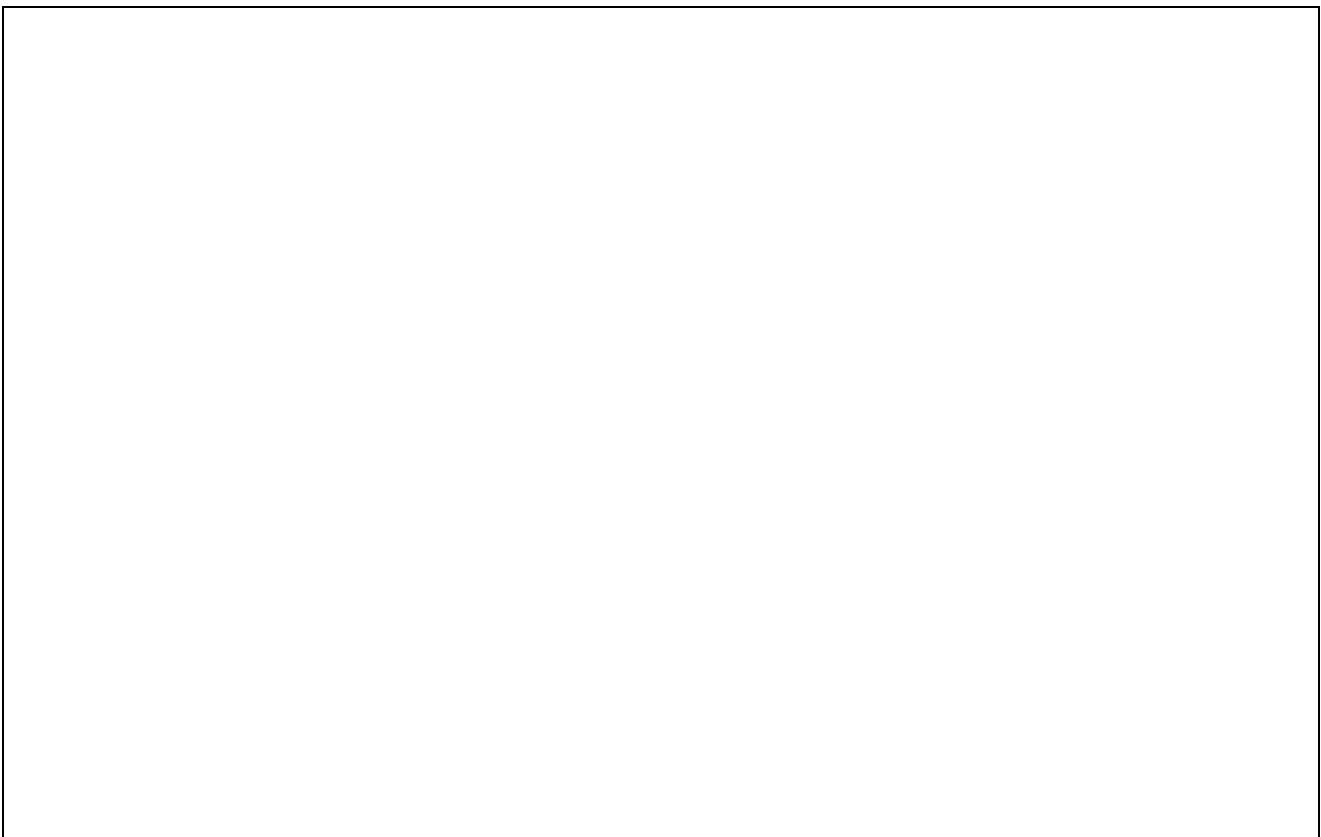

Chaine d'asservissement de la vitesse de levage du bateau :

21.

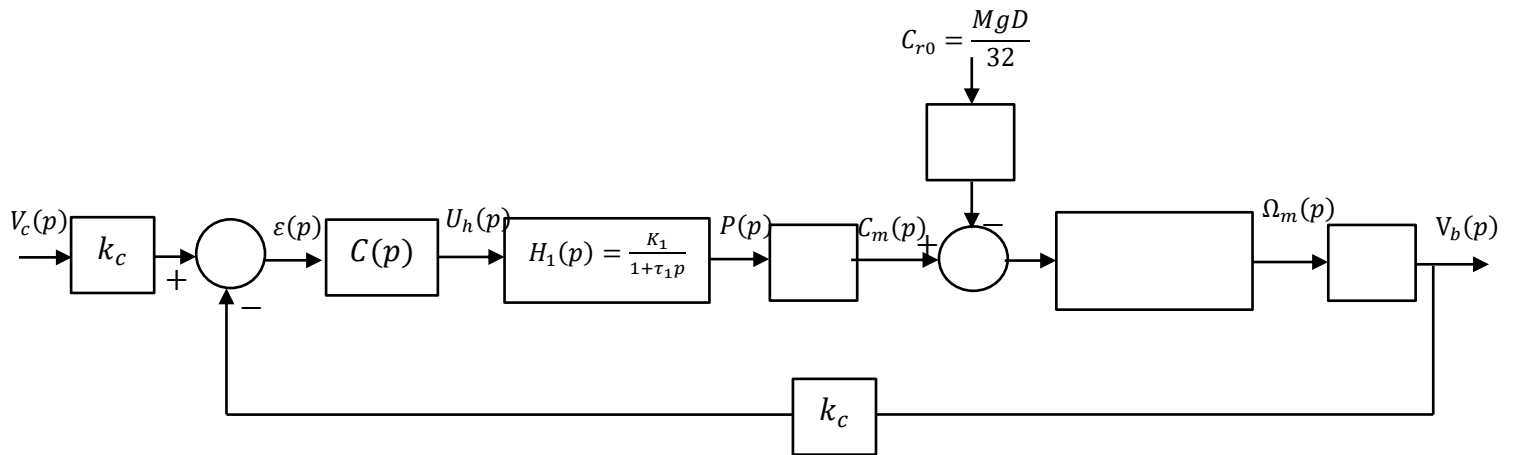
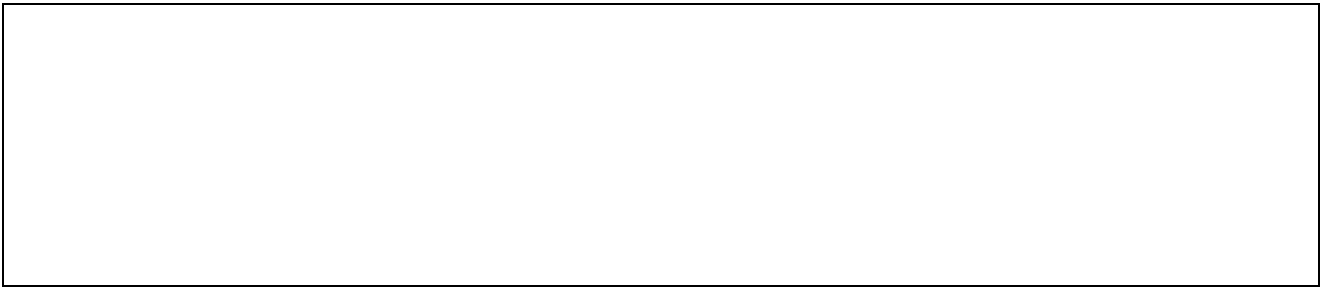

22.

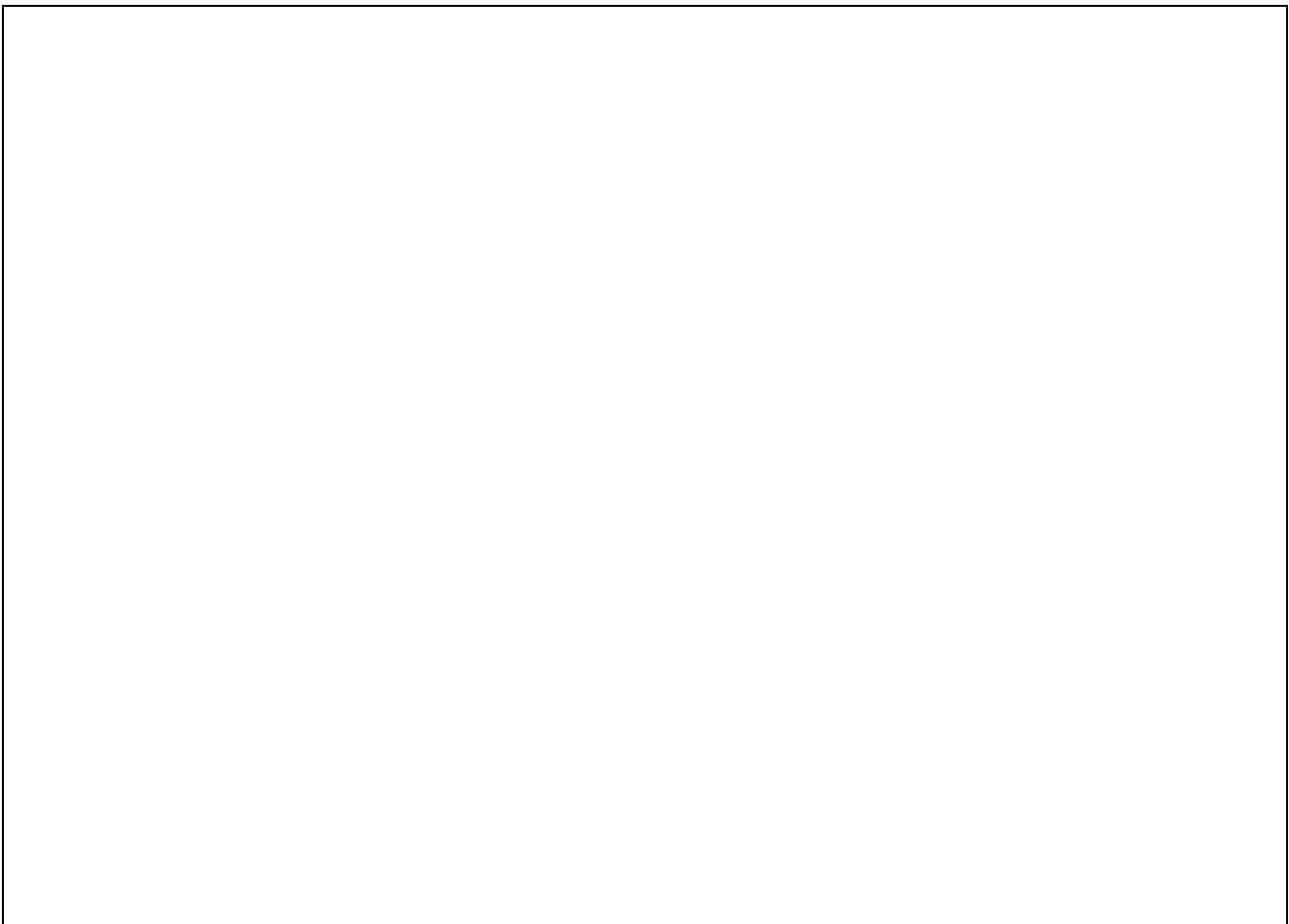

23.

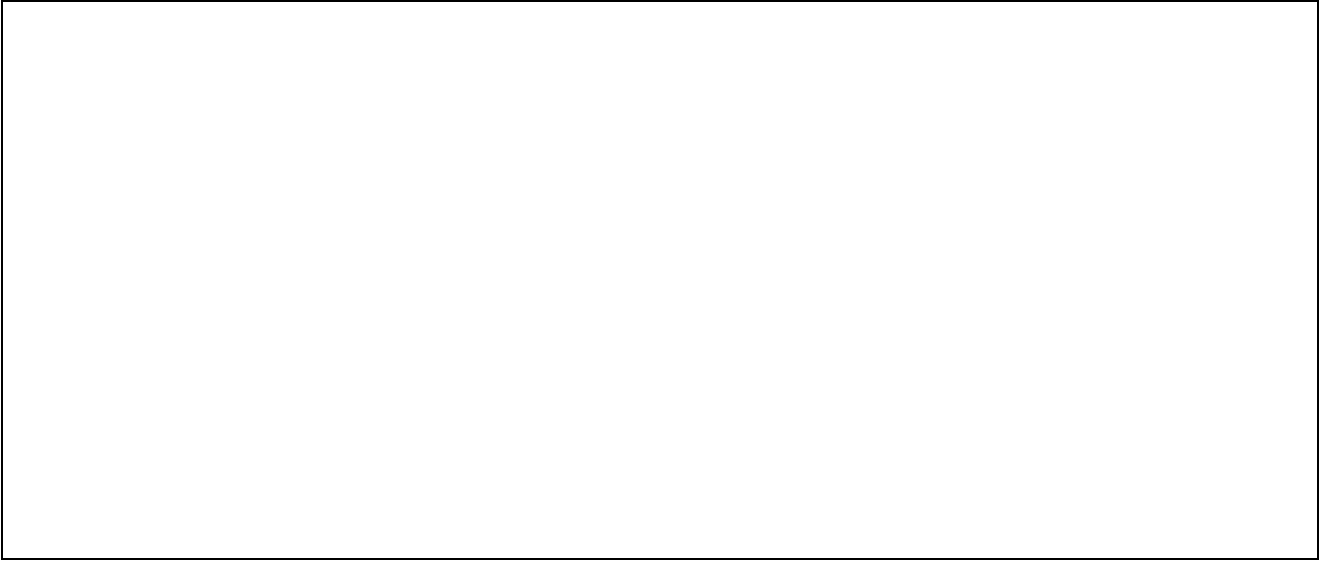

24.

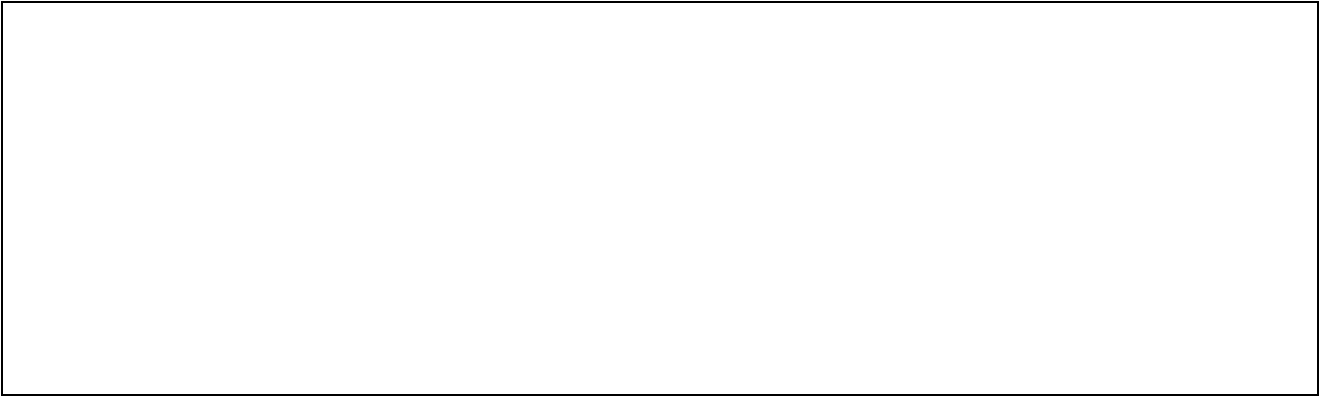

25.

